

BASKET STRAINER

Advantages:

Our Basket Strainers features top removal of the screen. The screen in the form of a basket, with a lifting handle, so that all particulate captured and retained by the screen can be easily removed for disposal. They are intended for applications where larger amounts of solid particulate are expected, and where clean-out will be frequent.

With Quick Opening Eye Bolts

- Our Fabricated Flanged Basket Strainers can be designed to your specific application.
- Strainers are available in Carbon Steel and Stainless Steel. 2" to 24" pipe sizes in Class 150 and Class 300 are available.
- Basket size can be tailored to hold sufficient solids for the required time clean-outs. Flange Sizes can be selected to fit existing piping or to achieve the required clean press drop.



Basket Strainer

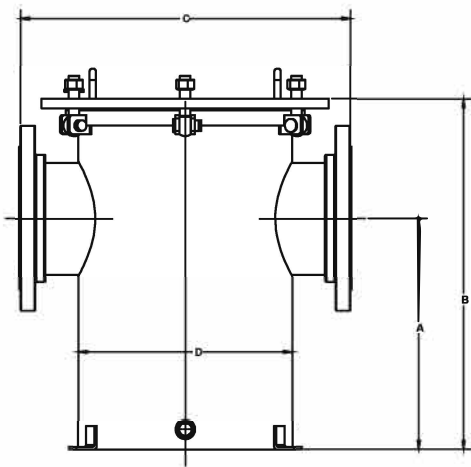

Size (I/O)	A (mm)	B (mm)	C (mm)	D (mm)
DN80	450	635	400	219
DN100	450	635	400	219
DN125	450	635	400	219
DN150	350	513	500	324